

## LM386 Low Voltage Audio Power Amplifier

### General Description

The LM386 is a power amplifier designed for use in low voltage consumer applications. The gain is internally set to 20 to keep external part count low, but the addition of an external resistor and capacitor between pins 1 and 8 will increase the gain to any value up to 200.

The inputs are ground referenced while the output is automatically biased to one half the supply voltage. The quiescent power drain is only 24 milliwatts when operating from a 6 volt supply, making the LM386 ideal for battery operation.

### Features

- Battery operation
- Minimum external parts
- Wide supply voltage range: 4V–12V or 5V–18V
- Low quiescent current drain: 4 mA

- Voltage gains from 20 to 200
- Ground referenced input
- Self-centering output quiescent voltage
- Low distortion
- Available in 8 pin MSOP package

### Applications

- AM-FM radio amplifiers
- Portable tape player amplifiers
- Intercoms
- TV sound systems
- Line drivers
- Ultrasonic drivers
- Small servo drivers
- Power converters

### Equivalent Schematic and Connection Diagrams

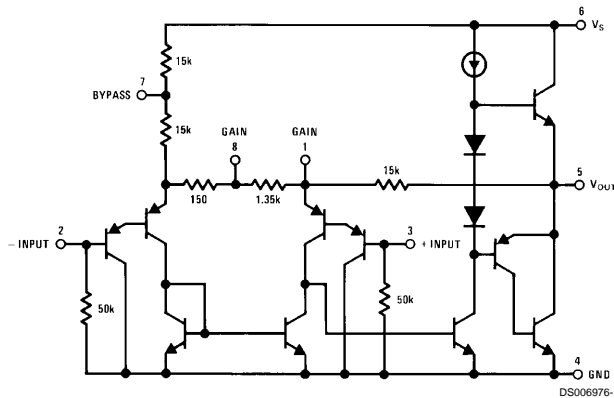

Dual-In-Line and Small Outline Packages

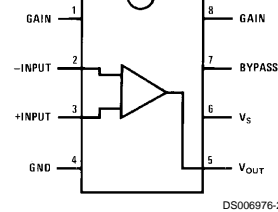

Top View  
Order Number LM386M-1,  
LM386MM-1, LM386N-1, LM386N-3  
or LM386N-4  
See NS Package Number  
M08A, MUA08A or N08E

## Typical Applications

Amplifier with Gain = 200  
Minimum Parts

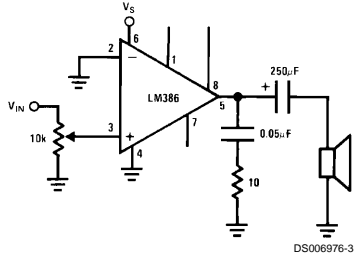

Amplifier with Gain = 200

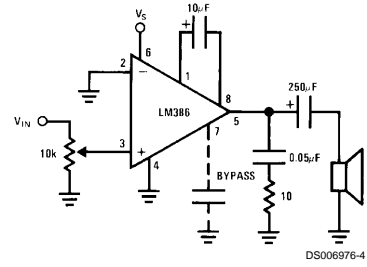

## Absolute Maximum Ratings (Note \*NO TARGET FOR FNxref NS0086\*)

If Military/Aerospace specified devices are required, please contact the National Semiconductor Sales Office/ Distributors for availability and specifications.

Supply Voltage	
(LM386N-1, -3, LM386M-1)	15V
Supply Voltage (LM386N-4)	22V
Package Dissipation (Note 1)	
(LM386N)	1.25W
(LM386M)	0.73W
Input Voltage	±0.4V
Storage Temperature	-65°C to +150°C
Operating Temperature	0°C to +70°C
Junction Temperature	+150°C

## Soldering Information

Dual-In-Line Package	
Soldering (10 sec)	+260°C
Small Outline Package	
Vapor Phase (60 sec)	+215°C
Infrared (15 sec)	+220°C

See AN-450 "Surface Mounting Methods and Their Effect on Product Reliability" for other methods of soldering surface mount devices.

## Thermal Resistance

$\theta_{JC}$ (DIP)	37°C/W
$\theta_{JA}$ (DIP)	107°C/W
$\theta_{JC}$ (SO Package)	35°C/W
$\theta_{JA}$ (SO Package)	172°C/W

## Electrical Characteristics

$T_A = 25^\circ\text{C}$

Parameter	Conditions	Min	Typ	Max	Units
Operating Supply Voltage ( $V_S$ )					
LM386N-1, -3, LM386M-1, LM386MM-1		4		12	V
LM386N-4		5		18	V
Quiescent Current ( $I_Q$ )	$V_S = 6V, V_{IN} = 0$		4	8	mA
Output Power ( $P_{OUT}$ )					
LM386N-1, LM386M-1, LM386MM-1	$V_S = 6V, R_L = 8\Omega, THD = 10\%$	250	325		mW
LM386N-3	$V_S = 9V, R_L = 8\Omega, THD = 10\%$	500	700		mW
LM386N-4	$V_S = 16V, R_L = 32\Omega, THD = 10\%$	700	1000		mW
Voltage Gain ( $A_V$ )	$V_S = 6V, f = 1\text{ kHz}$		26		dB
	10 $\mu\text{F}$ from Pin 1 to 8		46		dB
Bandwidth (BW)	$V_S = 6V, \text{Pins 1 and 8 Open}$		300		kHz
Total Harmonic Distortion (THD)	$V_S = 6V, R_L = 8\Omega, P_{OUT} = 125\text{ mW}$ $f = 1\text{ kHz, Pins 1 and 8 Open}$		0.2		%
Power Supply Rejection Ratio (PSRR)	$V_S = 6V, f = 1\text{ kHz, } C_{BYPASS} = 10\ \mu\text{F}$ Pins 1 and 8 Open, Referred to Output		50		dB
Input Resistance ( $R_{IN}$ )			50		k $\Omega$
Input Bias Current ( $I_{BIAS}$ )	$V_S = 6V, \text{Pins 2 and 3 Open}$		250		nA

**Note 1:** For operation in ambient temperatures above 25°C, the device must be derated based on a 150°C maximum junction temperature and 1) a thermal resistance of 80°C/W junction to ambient for the dual-in-line package and 2) a thermal resistance of 170°C/W for the small outline package.

## Application Hints

### GAIN CONTROL

To make the LM386 a more versatile amplifier, two pins (1 and 8) are provided for gain control. With pins 1 and 8 open the 1.35 k $\Omega$  resistor sets the gain at 20 (26 dB). If a capacitor is put from pin 1 to 8, bypassing the 1.35 k $\Omega$  resistor, the gain will go up to 200 (46 dB). If a resistor is placed in series with the capacitor, the gain can be set to any value from 20 to 200. Gain control can also be done by capacitively coupling a resistor (or FET) from pin 1 to ground.

Additional external feedback components can be placed in parallel with the internal feedback resistors to tailor the gain and frequency response for individual applications. For example, we can compensate poor speaker bass response by frequency shaping the feedback path. This is done with a series RC from pin 1 to 5 (paralleling the internal 15 k $\Omega$  resistor). For 6 dB effective bass boost:  $R \approx 15\text{ k}\Omega$ , the lowest value

for good stable operation is  $R = 10\text{ k}\Omega$  if pin 8 is open. If pins 1 and 8 are bypassed then  $R$  as low as 2 k $\Omega$  can be used. This restriction is because the amplifier is only compensated for closed-loop gains greater than 9.

### INPUT BIASING

The schematic shows that both inputs are biased to ground with a 50 k $\Omega$  resistor. The base current of the input transistors is about 250 nA, so the inputs are at about 12.5 mV when left open. If the dc source resistance driving the LM386 is higher than 250 k $\Omega$  it will contribute very little additional offset (about 2.5 mV at the input, 50 mV at the output). If the dc source resistance is less than 10 k $\Omega$ , then shorting the unused input to ground will keep the offset low (about 2.5 mV at the input, 50 mV at the output). For dc source resistances between these values we can eliminate excess offset by put-

## Application Hints (Continued)

ting a resistor from the unused input to ground, equal in value to the dc source resistance. Of course all offset problems are eliminated if the input is capacitively coupled.

When using the LM386 with higher gains (bypassing the 1.35 k $\Omega$  resistor between pins 1 and 8) it is necessary to by-

pass the unused input, preventing degradation of gain and possible instabilities. This is done with a 0.1  $\mu$ F capacitor or a short to ground depending on the dc source resistance on the driven input.

## Typical Performance Characteristics

**Quiescent Supply Current vs Supply Voltage**

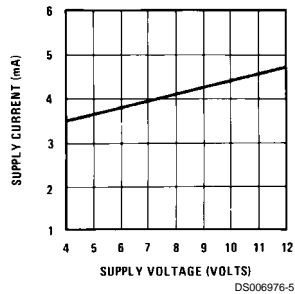

**Power Supply Rejection Ratio (Referred to the Output) vs Frequency**

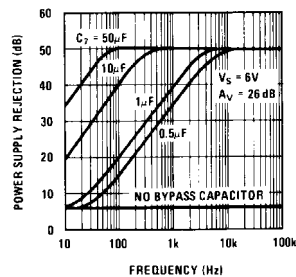

**Peak-to-Peak Output Voltage Swing vs Supply Voltage**

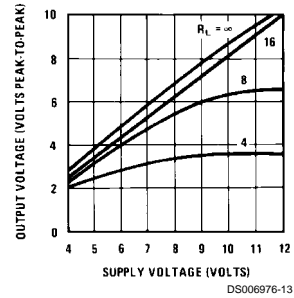

**Voltage Gain vs Frequency**

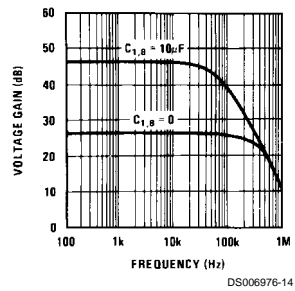

**Distortion vs Frequency**

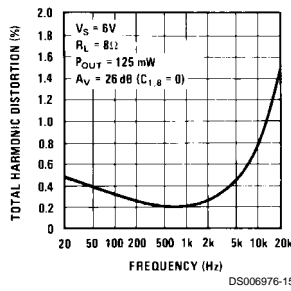

**Distortion vs Output Power**

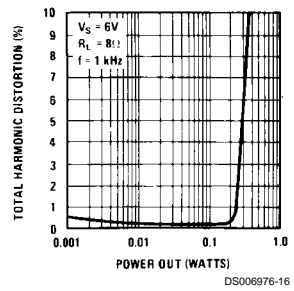

**Device Dissipation vs Output Power—4 $\Omega$  Load**

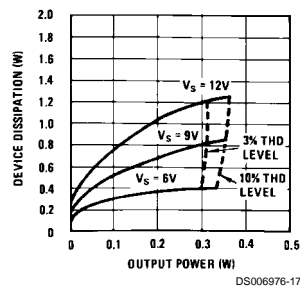

**Device Dissipation vs Output Power—8 $\Omega$  Load**

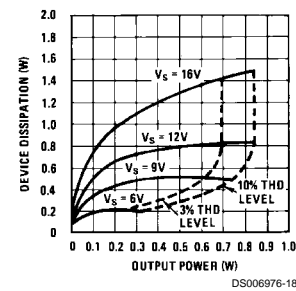

**Device Dissipation vs Output Power—16 $\Omega$  Load**

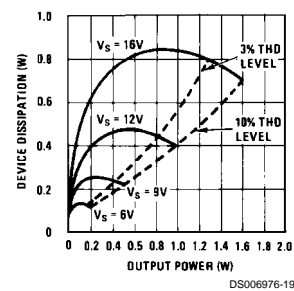

## Typical Applications

Amplifier with Gain = 50

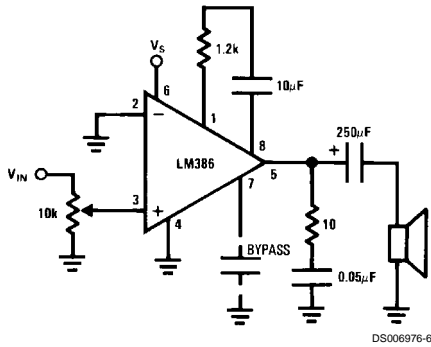

Low Distortion Power Wienbridge Oscillator

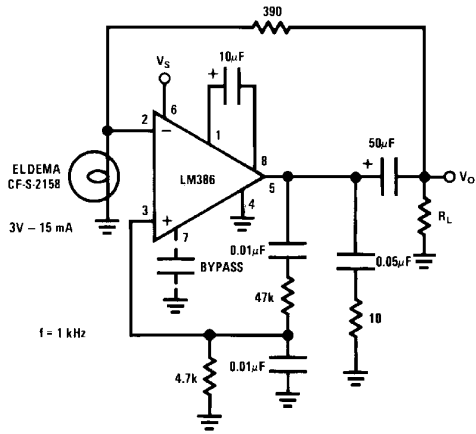

Amplifier with Bass Boost

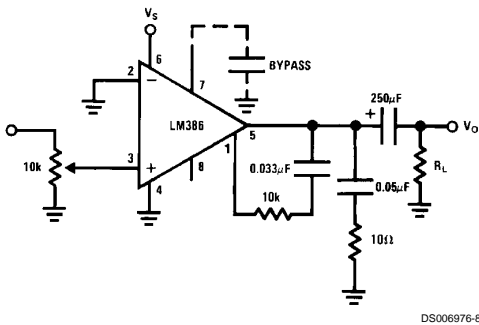

Square Wave Oscillator

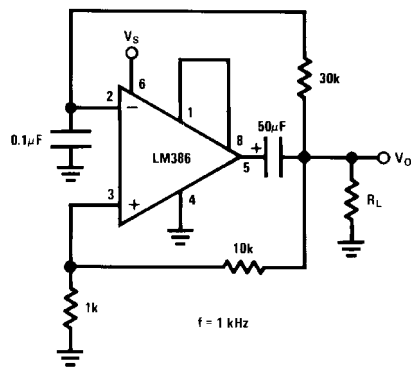

Frequency Response with Bass Boost

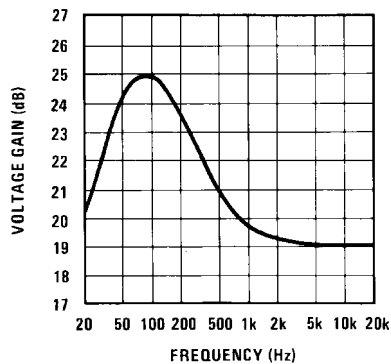

## Typical Applications (Continued)

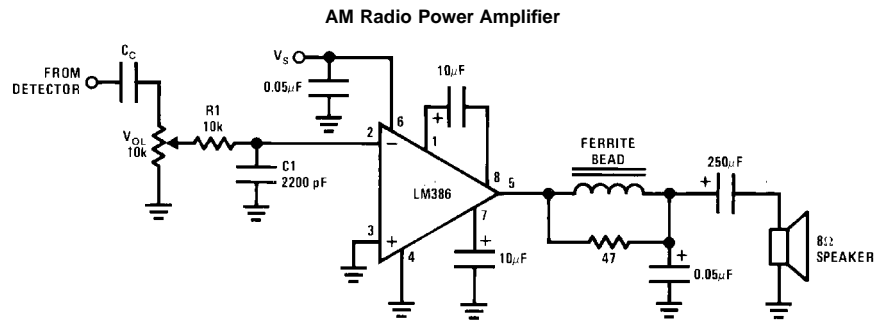

DS006976-11

**Note 2:** Twist Supply lead and supply ground very tightly.

**Note 3:** Twist speaker lead and ground very tightly.

**Note 4:** Ferrite bead in Ferroxcube K5-001-001/3B with 3 turns of wire.

**Note 5:** R1C1 band limits input signals.

**Note 6:** All components must be spaced very closely to IC.

Book  
Extract  
End



**Physical Dimensions** inches (millimeters) (Continued)

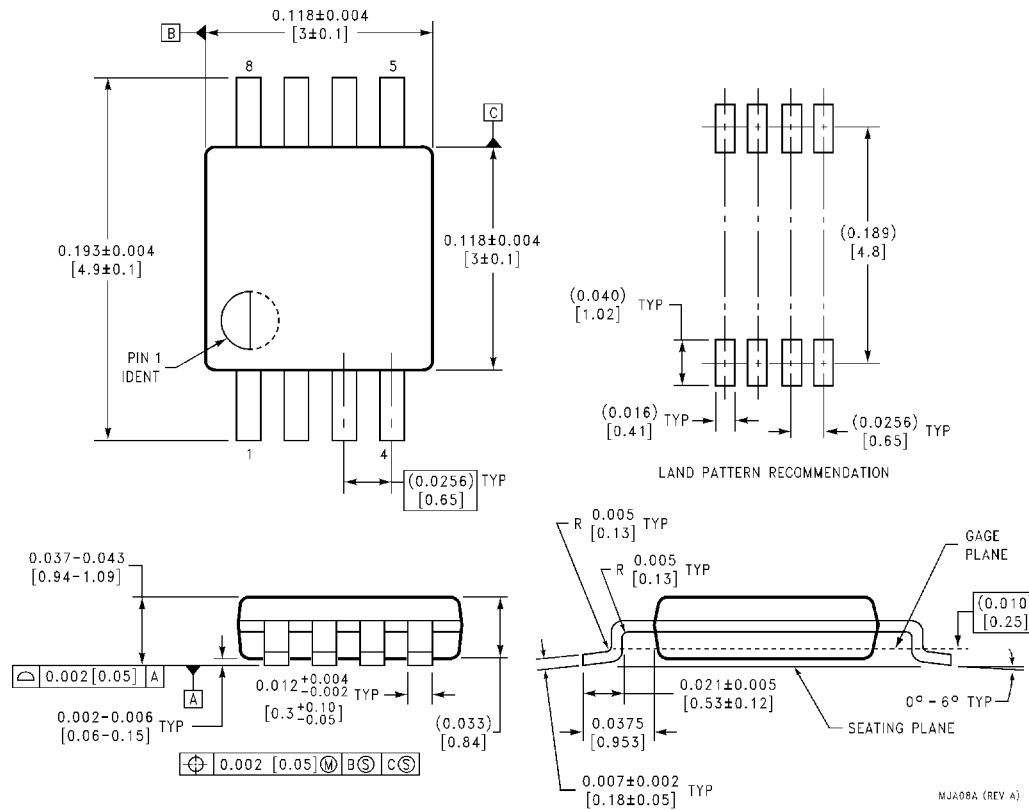

**8-Lead (0.118" Wide) Molded Mini Small Outline Package**  
**Order Number LM386MM-1**  
**NS Package Number MUA08A**

**LIFE SUPPORT POLICY**

NATIONAL'S PRODUCTS ARE NOT AUTHORIZED FOR USE AS CRITICAL COMPONENTS IN LIFE SUPPORT DEVICES OR SYSTEMS WITHOUT THE EXPRESS WRITTEN APPROVAL OF THE PRESIDENT OF NATIONAL SEMICONDUCTOR CORPORATION. As used herein:

1. Life support devices or systems are devices or systems which, (a) are intended for surgical implant into the body, or (b) support or sustain life, and whose failure to perform when properly used in accordance with instructions for use provided in the labeling, can be reasonably expected to result in a significant injury to the user.
2. A critical component in any component of a life support device or system whose failure to perform can be reasonably expected to cause the failure of the life support device or system, or to affect its safety or effectiveness.

 **National Semiconductor Corporation**  
 1111 West Bardin Road  
 Arlington, TX 76017  
 Tel: (800) 272-9959  
 Fax: (800) 737-7018  
<http://www.national.com>

**National Semiconductor Europe**  
 Fax: (+49) 0-180-530 85 86  
 Email: [cnjwge@tevm2.nsc.com](mailto:cnjwge@tevm2.nsc.com)  
 Deutsch Tel: (+49) 0-180-530 85 85  
 English Tel: (+49) 0-180-532 78 32  
 Français Tel: (+49) 0-180-532 93 58  
 Italiano Tel: (+49) 0-180-534 16 80

**National Semiconductor Hong Kong Ltd.**  
 13th Floor, Straight Block,  
 Ocean Centre, 5 Canton Rd.  
 Tsimshatsui, Kowloon  
 Hong Kong  
 Tel: (852) 2737-1600  
 Fax: (852) 2736-9960

**National Semiconductor Japan Ltd.**  
 Tel: 81-043-299-2308  
 Fax: 81-043-299-2408

National does not assume any responsibility for use of any circuitry described, no circuit patent licenses are implied and National reserves the right at any time without notice to change said circuitry and specifications.