

## **APR9301 RE-RECORDING VOICE IC** **Single-Chip Voice Recording & Playback Device** **for Single 20 to 30 Second Message**

### ■ **Features :**

- Single-chip, high quality voice recording & Playback solution
  - No external ICs required
  - Minimum external components
- Non-volatile Flash memory technology
  - No battery backup required
  - 100K record cycles (typical)
  - 100-year message retention (typical)
- Single message of 20 to 30 seconds, with external resistor selection
- Chip enable pin for simple message expansion
- User-friendly, easy-to-use operation
  - Programming & development systems not required
  - Level-activated recording & edge-activated playback switches
- Low power consumption
  - Operating current: 25mA (typical, no load)
  - Standby current: 1uA (typical, no load)
- Automatic power-down feature for longer battery life
- Single 5V power supply

### **General Description :**

The APR9301 device offers true single-chip solid-state storage capability and requires no software or microcontroller support. It provides high-quality recording and playback with a single 20- to 30-second message. It is ideal for portable voice recorders, toys, and many other consumer and industrial applications.

APLUS's proprietary analog/multi-level storage technology is implemented in advanced Flash non-volatile memory cells, each of which can typically store more than 256 voltage levels. The APR9301 device stores and reproduces voice signals in their natural forms, eliminating distortion that is often introduced by encoding and compression. The device combines a small size with low power consumption, non-volatility, and ease-of-use for a cost effective solution to voice recording and playback

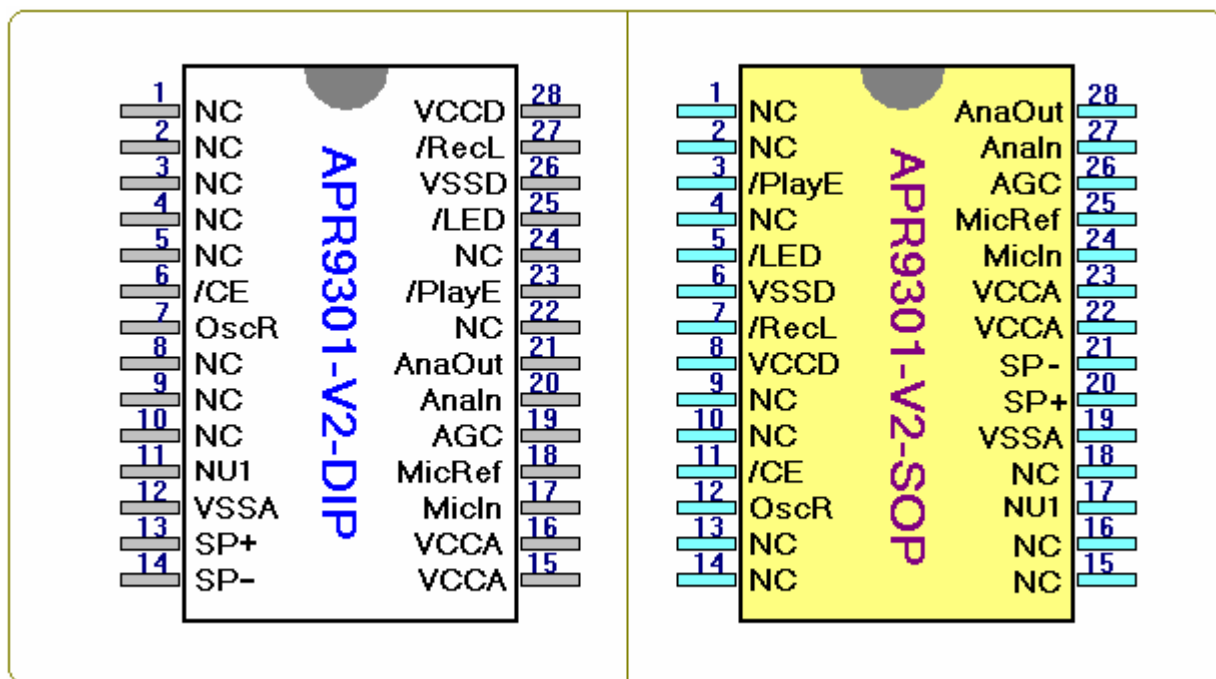

PS : The APR9301 DIP & SOP is not [ PIN to PIN ]

■ Functional Block Diagram :

Figure 2 shows the functional block diagram for the APR9301 device.

Figure 2 APR9301 Functional Block Diagram

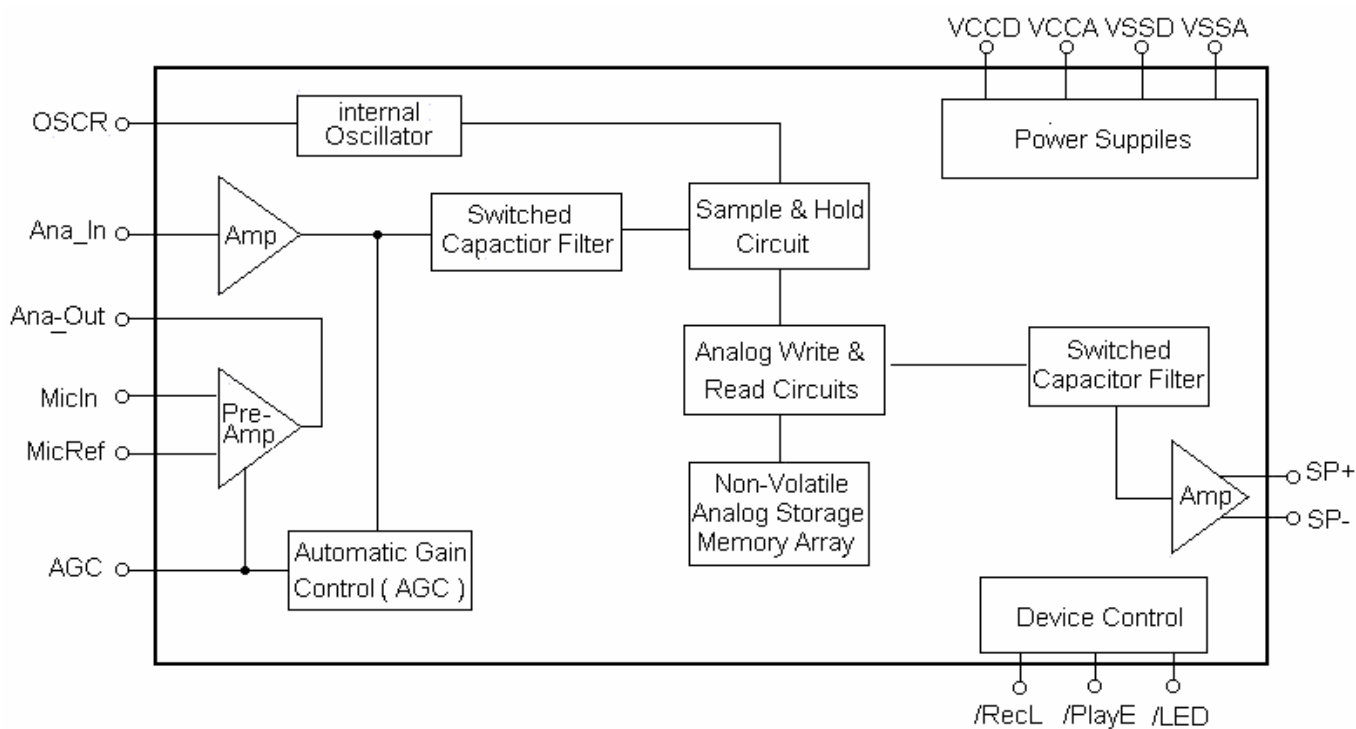

## Sample Application

Figure 3 shows the diagram for a single, 20-second message recording and playback application using the APR9301 device. When pins are connected as shown in this example, the operating modes are as follows:

### Record Mode (Level-Activated)

A single voice message of up to 20 seconds can be recorded. The /LED pin will go low during the actual recording process to provide a visual indication if an LED light is connected to this pin. The chip is in record mode as long as the /RecL pin stays low level-activated). If the message lasts longer than 20 seconds, recording will terminate automatically after the last available memory cell is written. If the message is shorter than 20 seconds, the recording operation will stop when the /RecL pin goes high. The speaker driver is automatically tristated during the recording operation. Messages of up to 30 seconds can be recorded by using different OscR resistor values (see Table 1).

### Playback Mode (Edge-Activated)

Playback always starts from the beginning of the message. The chip is in playback mode after the /PlayE pin pulses low (edge-activated). Playback will stop immediately when the /PlayE pin pulses low a second time.

If the newly recorded message is shorter than the previously recorded message, the remaining portion of the previous message will not be played after the new message is played back.

The input preamplifier, AGC, and main amplifier circuits are disabled during playback.

### Standby Mode (/CE = "0)

The chip will automatically return to the standby state after recording or playback operation is completed.

### Power Down Mode (/CE = "1 `)

The chip is always in standby state.

No recording or playback is allowed. Current consumption is typically less than 1uA.

Figure 3 Sample Application for the APR9301 :

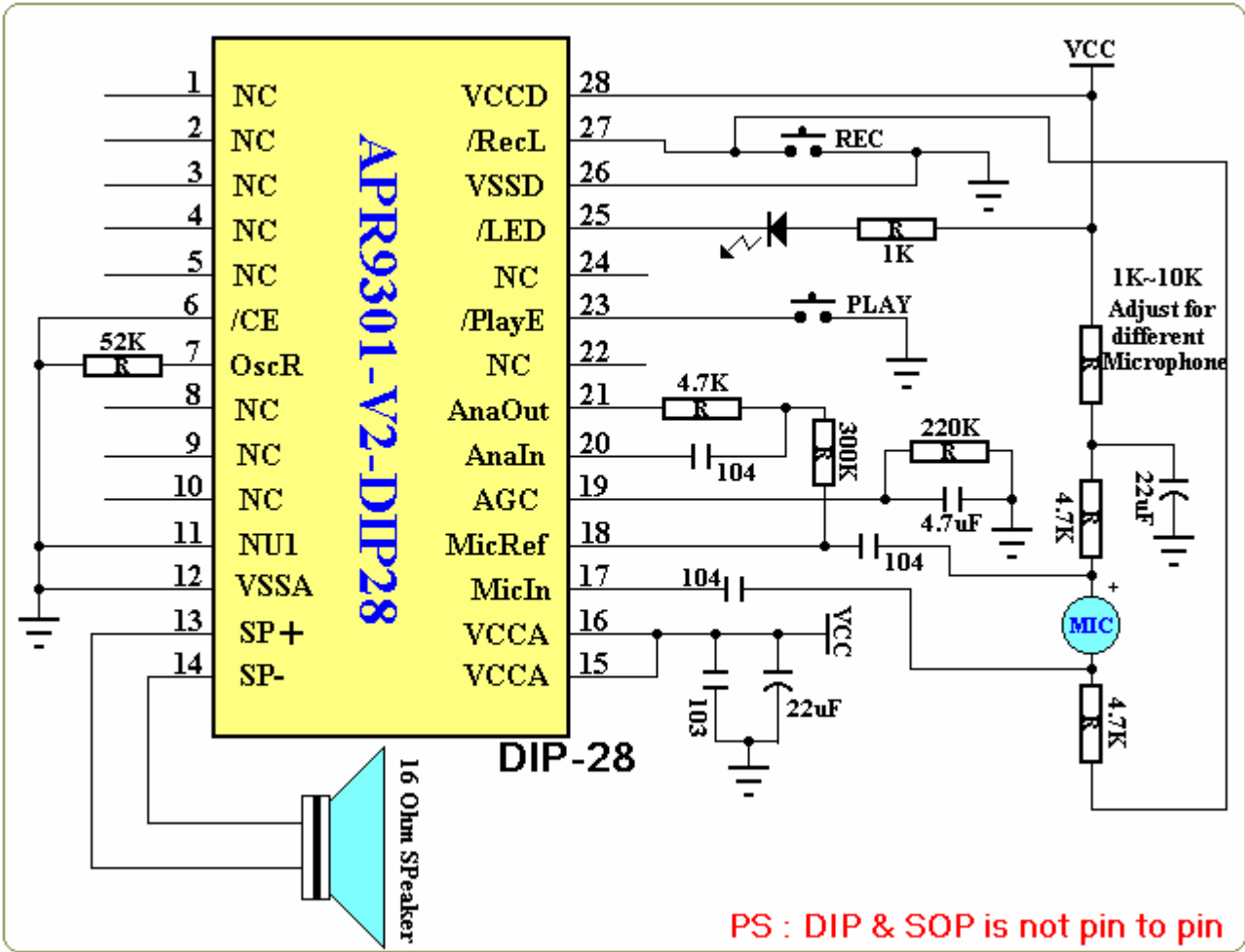

NC=No Connect (must be floating)  
 Pins 23 and 27 have internal pull-up resistors.  
 The typical sampling frequency is 6.4kHz with OscR=52K $\omega$

Table 1 Typical Dependence of Sampling Frequency and Total Voice Duration on OscR Resistor Value

(VccA = VccD = 5V; VssA = Vssd = 0V; TA = 25°C)

OscR value	Sampling Frequency Typical	Cutoff Frequency (3dB Point)	Total Voice Duration Typical	Working Voltage
38k $\Omega$	8kHz	3.4kHz	16 SECONDS	4.5V ~ 6.5V
52k $\Omega$	6.4kHz	2.7kHz	20 SECONDS	4.5V ~ 6.5V
67k $\Omega$	5.3kHz	2.3kHz	24 SECONDS	4.8V ~ 6.5V
75k $\Omega$	4.5kHz	2kHz	30 SECONDS	5.2V ~ 6.5V



### Absolute Maximum Ratings

Stresses greater than those listed in Table 2 may cause permanent damage to the device. These specifications represent a stress rating only. Operation of the device at these or any other conditions above those specified in the recommended DC Characteristics or recommended Analog Characteristics of this specification is not implied. Operation of the device at maximum conditions for extended periods may affect reliability.

**Table 2 Absolute Maximum Ratings.**

Item	Symbol	Condition	Min	Max	Unit
Power Supply Voltage	Vcc	TA = 25°C	4.5	6.5	V
Input Voltage	VIN1	TA = 25°C	-0.3	Vcc + 0.3	V
Input Voltage	VIN2	IIN   < 20 mA	-1.0	Vcc + 1.0	V
Storage Temperature	TSTG	--	-65	150	°C
Temperature Under Bias	TBS	--	-65	125	°C
Lead Temperature	TLD	< 10s	--	300	°C

**Table 3 DC Characteristics ( Note 1 )**

Item	Symbol	Condition	Mm	Typ	Max	Unit
Input High Voltage	VIH	--	0.8 x Vcc	--	--	V
Input Low Voltage	VIL	--	--	--	0.8	V
Output High Voltage	VOH	IOL = -1.6mA	2.4	--	--	V
Output Low Voltage	VOL	IOL = 4.0mA	--	--	0.45	V
Input Leakage Current	IiH	VIH = Vcc	--	--	1.0	uA
Input Leakage Current	IiL	VIL = Vss(Note 2)	-1.0	--	--	uA
Output Tristate Leakage Current	Ioz	VOUT = VCC or VOUT=VSS	-1.0	--	1.0	uA
Operating Current Consumption	Icc	Internal Clock, No Load	--	25	--	mA
Standby Current Consumption	Iccs	No Load	--	1.0	--	uA

**Table 4 Analog Characteristics ( Note 1 )**

Item	Symbol	Condition	Mim	Typ	Max	Unit
MicIn Input Voltage	VMI	--	--	--	20	mVp-p
MicIn Input Resistance	RMI	--	--	10	--	kΩ
MicIn Amp Gain (1)	GMII	AGC ≤ 2.2V	--	24	--	dB
MicIn Amp Gain (2)	GMI2	AGC ≥ 3.0V	--	-45	-15	dB
AnaIn Input Voltage	VANI	--	--	--	50	mVp-p
AnaIn Input Resistance	RANI	--	--	10	--	kΩ
AnaIn Amp Gain	GANI	AnaIn to SP+/-	--	22	--	dB
AGC Output Resistance	RAGC	--	--	1	--	kΩ
SP+/- Output Power	Psp	Rsp+/- = 16Ω	--	12.2	--	mW
Voltage Amplitude Across SP+/-	Vsp	Rsp+/- ≥ 16Ω	--	1.25	--	Vp-p
Total Harmonic Distortion	THD	@ 1kHz & 20mVp-p input		1		%

Note 1: Typical Values: VCCD = VCCA = 5V; VSSD = VSSA = 0V; TA = 25°C

Note 2: Except pins 23 and 27 which have internal pull-up resistors.

**Bonding Pad Diagram & Description of Bonding Pad Coordinates :**

**Figure 5 APR9301 Die Bonding Pad Diagram**

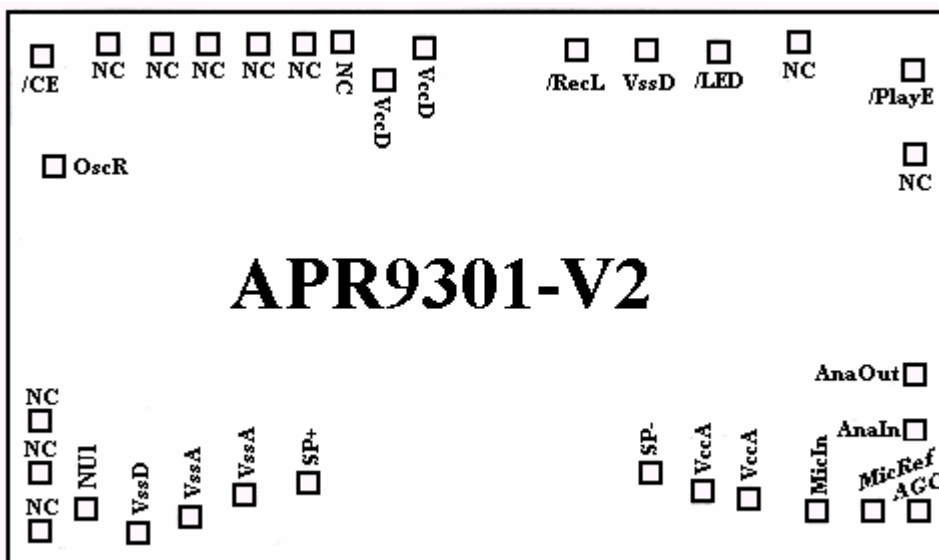

**Notes:**  
Die diagram is with respect to die center(um)

**Die Dimensions:**  
X=214± 1 mils(5500um)  
Y=144± 1 mils(3750um)

**Die Thickness:**  
13.8± 1.0 mils  
(350± 25um)

**Pad Opening:**  
4.3mils  
110um

\* **Connect substrate to Ground.**

**Table 5 APR9301 Bonding Pad Coordinates :**

Pin	Pin Name	X - Axis (Note)	Y - Axis (Note)
/CE	Chip Enable	-2496.2	1565.8
OscR	Oscillator Frequency-Setting Resistor	-2459.55	729.8
NU1	Connect to Ground	-1808.45	-1496.1
VSSD	Digital Ground Supply	-1564.05	-1572
VSSA	Analog Ground Supply	-1384.05	-1548.7
VSSA	Analog Ground Supply	-1204.35	-1477.1
SP+	Non-Inverting Speaker Output	-707.15	-1390
SP-	Inverting Speaker Output	479.15	-1389.9
VCCA	Analog Power Supply	976.45	-1492
VCCA	Analog Power Supply	1190.4	-1523.7
MinIn	Microphone Input	1619.45	-1551.4
MicRef	Microphone Reference Input	2035.45	-1551.4
AGC	Automatic Gain Control	2487.45	-1551.4
AnaIn	Analog Signal Input	2487.45	-1049.9
AnaOut	Analog Signal Output	2487.45	-648.9
/PlayE	Edge-Activated Playback	2493.65	1371.1
/LED	LED Output	1430.7	1565.8
VSSD	Connect to Ground	865.75	1565.8
/Recl	Level-Activated Record	258.15	1565.8
VCCD	Digital Power Supply	-229.4	1579.05
VCCD	Digital Power Supply	-510.8	1541.6

Note: With respect to die center(um)

■ PACKAGE OUTLINE : SOP - 28 ( 330 MIL )

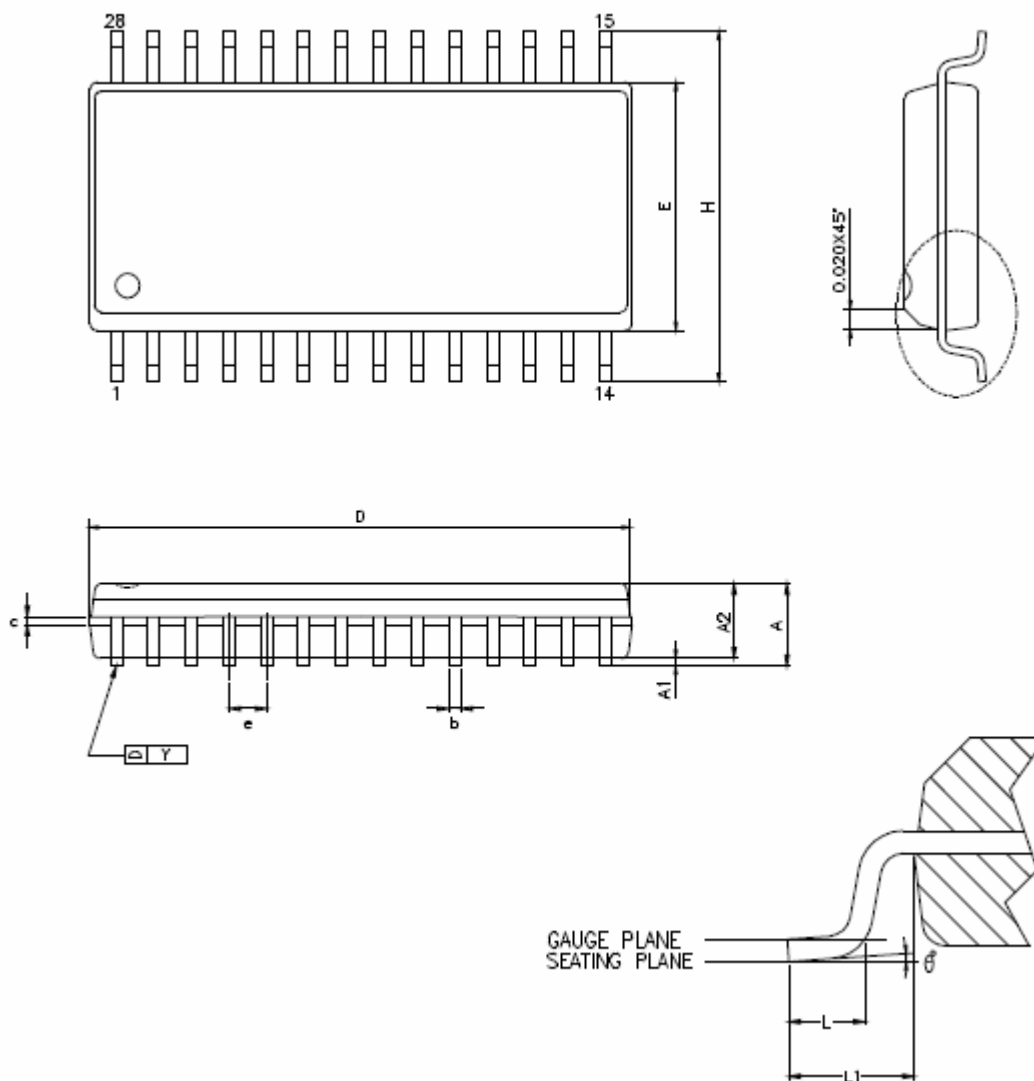

	SYMBOLS	MIN.	NOM.	MAX.
	A	—	—	0.112
△	A1	0.002	—	—
△	A2	0.094	0.098	0.102
	b	0.014	0.016	0.020
	c	0.008	0.010	0.014
△	D	0.708	0.713	0.718
	E	0.324	0.331	0.336
	H	0.453	0.465	0.477
	e	0.044	0.050	0.056
△	L	0.028	0.036	0.038
	L1	0.059	0.067	0.075
	Y	—	—	0.004
	θ°	0	—	10°

UNIT : INCH

NOTES:

1. JEDEC OUTLINE : MO-059 AD
2. DIMENSIONS "D" DOES NOT INCLUDE MOLD FLASH, PROTRUSIONS OR GATE BURRS. MOLD FLASH, PROTRUSIONS AND GATE BURRS SHALL NOT EXCEED .15mm (.006in) PER SIDE.
3. DIMENSIONS "E" DOES NOT INCLUDE INTER-LEAD FLASH, OR PROTRUSIONS. INTER-LEAD FLASH AND PROTRUSIONS SHALL NOT EXCEED .25mm (.010in) PER SIDE.

■ PACKAGE OUTLINE : DIP - 28 ( 600 MIL )

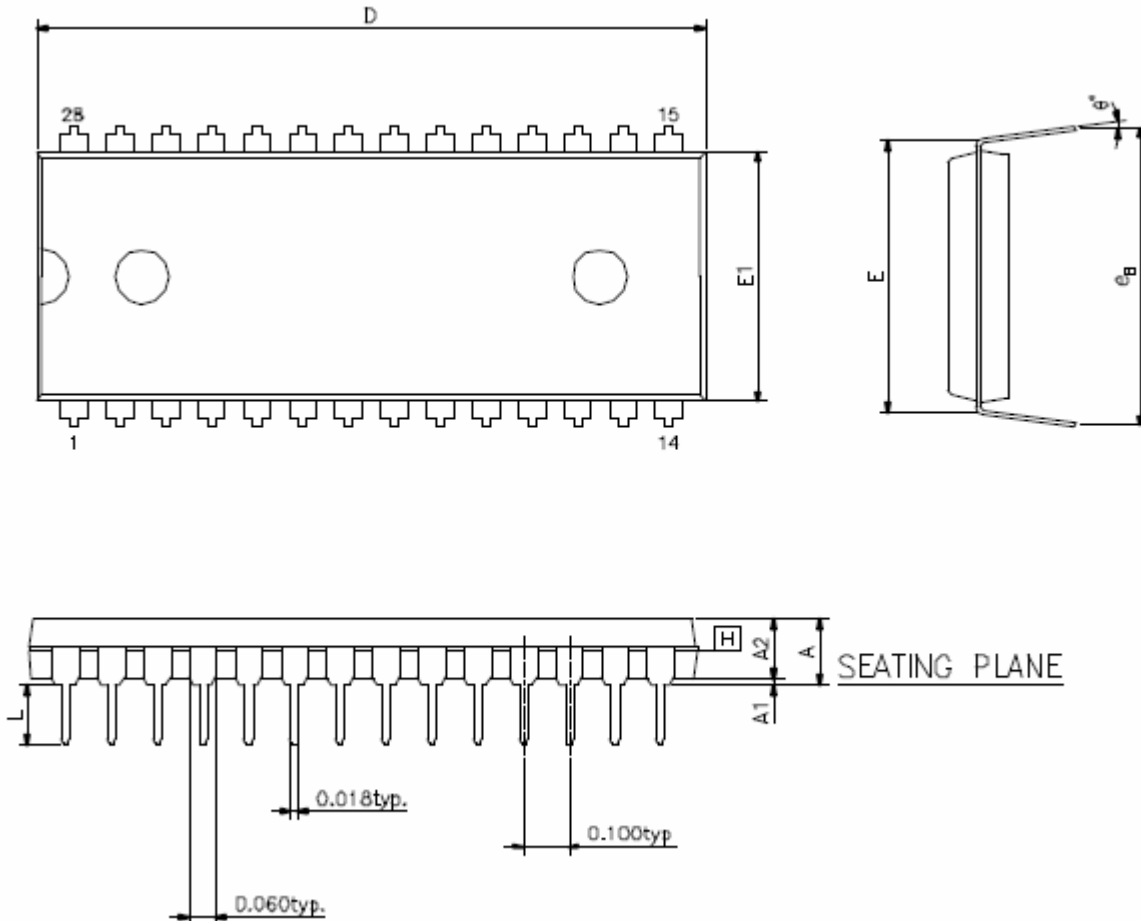

SYMBOLS	MIN.	NOR.	MAX.
A	—	—	0.220
A1	0.015	—	—
A2	0.150	0.155	0.160
D	1.455	1.460	1.470
E	0.600 BSC		
E1	0.540	0.545	0.550
L	0.115	0.158	0.200
e <sub>B</sub>	0.630	0.650	0.670
θ	0	7	15

UNIT : INCH

NOTE:

1. JEDEC OUTLINE : MS-011 AB
2. E1 DOES NOT INCLUDE MOLD FLASH.

OPERATION GUIDE for APR9301 Demo Board

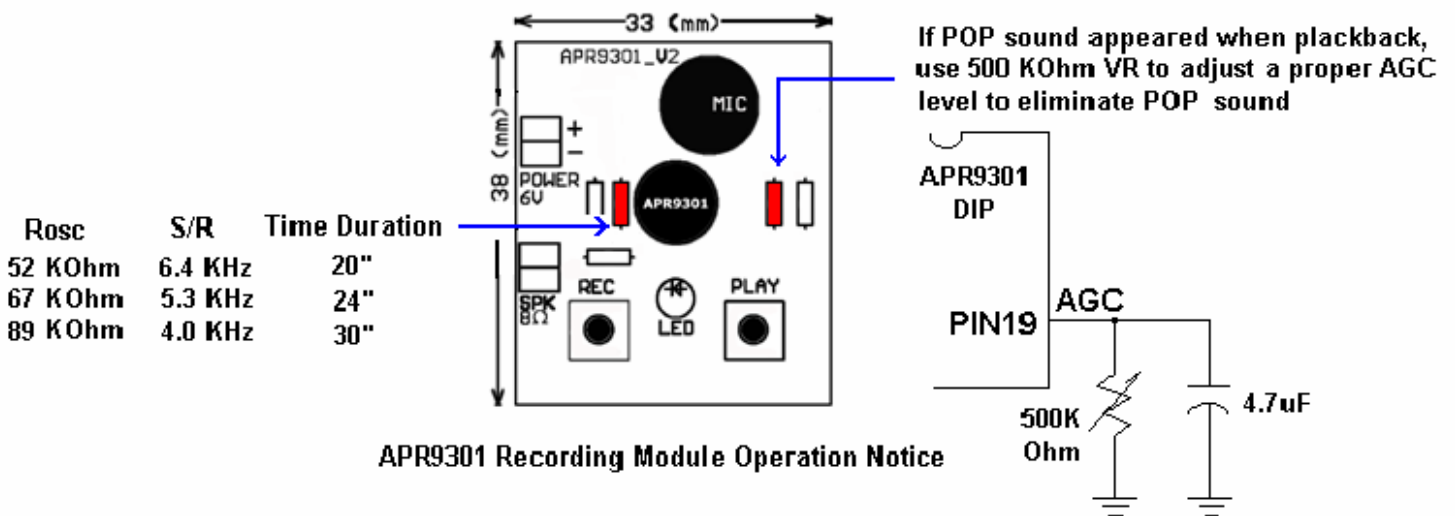

- Step1. Connect 6V DC to the Demo Board.
- Step2. Connect Speaker to Demo Board.
- Step3. Press & hold on the 'RECORD' Key.
- Step4. Say something toward the Microphone about 20 - 30 seconds.
- Step5. Release 'RECORD' Key.
- Step6. Press 'PLAY' Key one time (needn't hold it on) to play the voice you had recorded.